

# AS15B30H

**STANDARD MATERIALS AND CONSTRUCTION**

**FRAME:** .063" thk. (nominal) extruded aluminum, 6063-T52/T6 alloy.

**BLADE:** .063" thk. (nominal) extruded aluminum, 6063-T52/T6 alloy.  
Blades approximately 1 1/2" on center.

**LOUVER FACE:** All surfaces are flush, with jambs contained within head and sill.

**SCREEN:** (When indicated.)

1/2" flattened aluminum (.051" thick),

-or- 1/2" sq. mesh, intermediate double-crimped aluminum wire, .063" dia.,

-or- 19/16 mesh, .011" dia. aluminum wire, insect screen.

**FINISH:** Mill

**OPTIONS**

Finish - Baked Enamel, Kynar, Anodize

**NOTES**

1. Nominal deductions will be made to the opening size given.
2. Approximate shipping weight is 3.8 lbs./sq.ft.

**LOUVER SIZES**

Min Panel	Max Single Panel
12"W x 12"H	60"W x 96"H

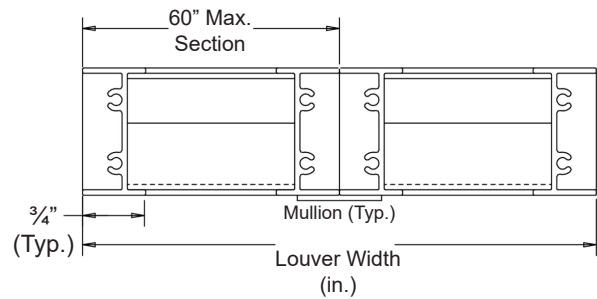
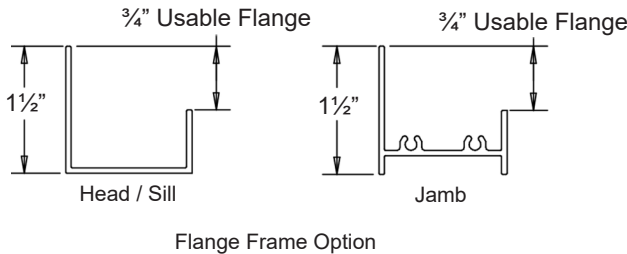
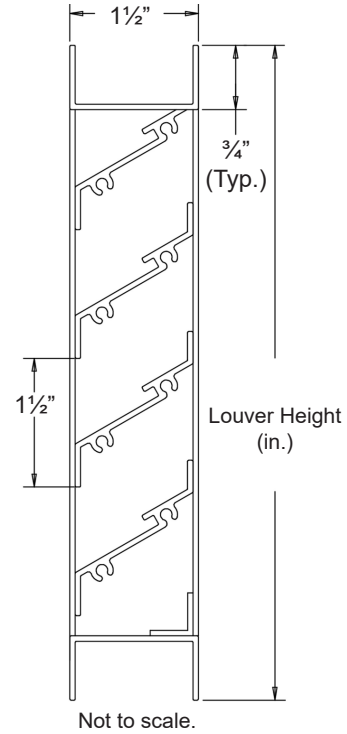

In the interest of product development, Airline Louvers reserves the right to make changes without notice.

										
<b>Item #</b>	<b>Qty</b>	Width	Height	Width	Height	<b>Mullion</b>	Type	Location		
		<b>Opening Size</b>		<b>Louver Size</b>			<b>Screens</b>			<b>Union Made</b>
<b>Arch. / Eng. :</b>						<b>EDR:</b>	<b>ECN:</b>	<b>Job:</b>		
<b>Contractor:</b>										
<b>Project:</b>						<b>Date:</b>	<b>DWN:</b>	<b>DWG:</b>		

# AS15B30H

### PERFORMANCE DATA

Pressure Drop: .034 in. w.g. at 495 fpm (Intake)  
 Free Area: 7.37 sq.ft. = 46.06% for 48"W x 48"H sample tested in accordance with AMCA Standard 500-L.  
 Beginning Point of Water Penetration: 459 fpm

Ratings do not include effects of a screen.

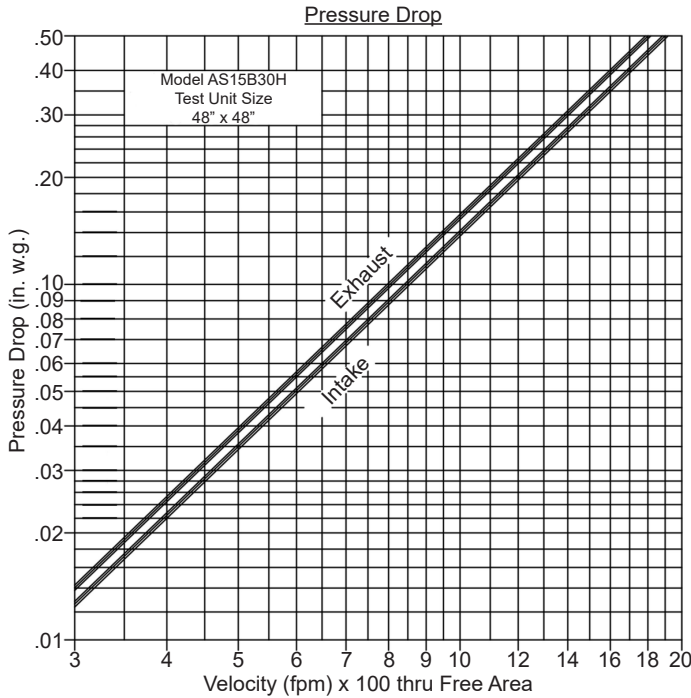

Intake air converted to standard air density.  
 Tested to AMCA Standard 500-L, Figure 5.5.

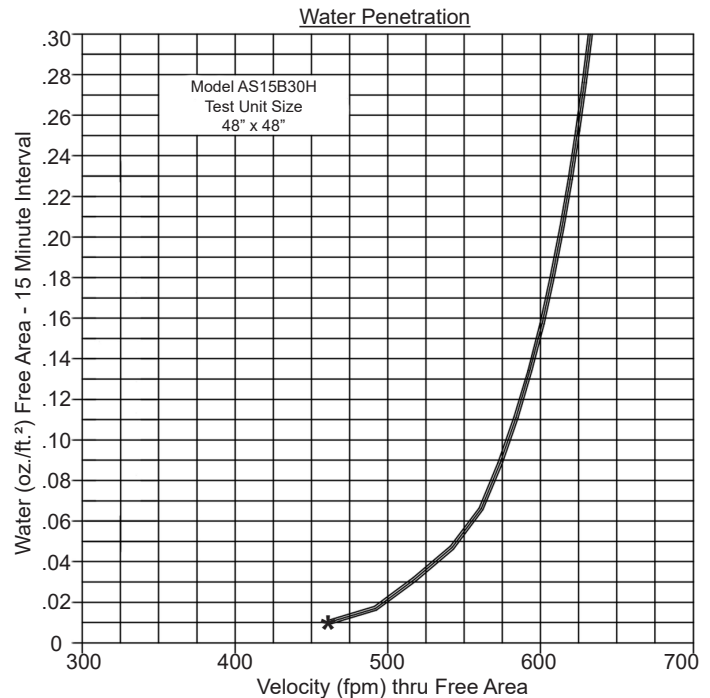

459 (FPM) Beginning Point of Water Penetration

Free Area (sq.ft.)

		Width (in.)								
		12"	18"	24"	30"	36"	42"	48"	54"	60"
Height (in.)	12"	.33	.52	.71	.90	1.09	1.28	1.47	1.66	1.85
	24"	.78	1.22	1.66	2.11	2.55	2.99	3.44	3.88	4.32
	36"	1.22	1.92	2.61	3.31	4.01	4.70	5.40	6.10	6.80
	48"	1.66	2.61	3.56	4.52	5.47	6.42	7.37	8.32	9.27
	60"	2.11	3.31	4.52	5.72	6.92	8.13	9.33	10.54	11.74
	72"	2.55	4.01	5.47	6.93	8.38	9.84	11.30	12.76	14.22
	84"	3.00	4.71	6.42	8.13	9.84	11.55	13.27	14.98	16.69
	96"	3.44	5.40	7.37	9.34	11.30	13.27	15.23	17.20	19.16

AMCA registered laboratory is a laboratory equipped and staffed to conduct tests according to the appropriate AMCA test methods and which has been licensed as an AMCA registered laboratory.